

SMOKE EXTRACTION



DIABLO®

RANGE

Smoke extraction unit F400-120
Flow rates from 300 to 35000 m³/hr
under pressures of 50 to 700 Pa.
in compliance with NF EN 12101-3

02

DIABLO®



DIABLO TWIN®





ERP2016
CALADAIR RESPECT

DIRECT COUPLED UNIT DESCRIPTION

DIABLO®



DIABLO®



Certificate number
0679 - CPR - 0949

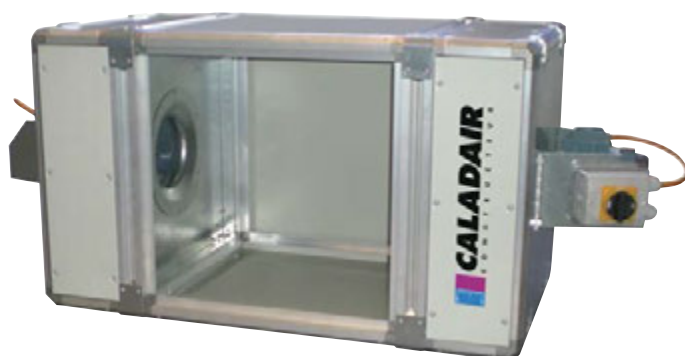

DIABLO TWIN®

APPLICATION

- Smoke extraction units meeting legislative requirements for the extraction of smoke and hot gases in the event of fire in high rise buildings and public assembly buildings.
- Range also designed for the extraction of contaminated air from industrial premises, professional kitchens and car parks, etc.
- ▲ The **DIABLO®**, **DIABLO TWIN®** programme is F400-120 approved by the CSTB and covered by the CE certificate for smoke and heat extractor fans in compliance with standard NF EN 12101-3.

RANGE

- Available in 3 sizes and 10 models, the **DIABLO®** version covers flow rates from 300 to 18000 m³/h under pressures from 50 to 700 Pa. The **DIABLO TWIN®** version, made up of 2 motorised fan units, provides flow rates of 300 to 35000 m³/h.

CONSTITUTION

- Aluminium supporting frame reinforced by a galvanized chassis for **DIABLO TWIN®** 630 to 800.
- ▲ Removable and interchangeable panels in 10/10 RAL7035 pre-lacquered galvanised metal sheet.
- Set of feet for fixing to the floor.
- ▲ Wide access for the cleaning and maintenance of the fan whatever the installation configuration.
- Motor fan support consisting of a galvanised steel plate strengthened by raised edges.
- Galvanised steel reaction impeller (high performance and easy to clean), statically balanced, fitted with an aluminium hub a directly coupled to the motor.
- Motor: B3 motor, protection IP 55 class F
 - 230V, 50Hz Single-phase motor with permanent condenser.
 - 1 speed 230/400V 50 Hz three-phase motor.
 - 2-speed, 400V 50Hz three-phase motor, Dahlander winding (4/8 and 6/12P), independent windings (4/6 and 6/8P).

INSTALLATION

- ▲ The **DIABLO®** range can be installed in all positions. The side panels in RAL7035 pre-lacquered galvanized metal sheet are interchangeable and thus enable the unit to be connected in numerous installation configurations: in line, intake on the left and discharge at 90° to the right and/or left, intake above outlet to the left and/or right, etc.
- Can be used indoors or outdoors (see installation options).

VARIANTS F400-120 APPROVED BY THE CSTB

- Acoustic insulation in very high density 25 mm 120 kg/m³ mineral wool providing powerful acoustic attenuation (DIP option).
- Double skin insulation (DDP), standard external face in 10/10 RAL7035 galvanised sheet, internal face in 10/10 galvanised sheet and insulation in high density mineral wool, 25 mm - 60 kg/m³. Recommended for installations requiring regular maintenance of the unit while providing attenuation of the sound levels radiated (professional kitchens, etc.).
- Condensate tray at bottom of unit (DEC option) for removal of condensates.

OPTIONS

- ▲ Numerous installation, operating, control and regulation options are available and approved F400-120 by the CSTB (see page 266).



Unit model	Motor type	Puissance Moteur kW	Intensité Nominale A	DIABLO® Variant	DIABLO TWIN® Variant	Weight DIABLO®	Unit (kg) DIABLO TWIN®
DIABLO® 280	MONO	0,25	2,15	VATM 2,2 - CATM 022	VATM 5 - CATM 050	53	90
	A6	0,18	0,64	VFM/T 037	VFM/T 075	54	91
	B4	0,37	1,1	VFM/T 037	VFM/T 075	51	93
	B48	0,37 / 0,09	1,32 / 0,5	-	-	55	93
DIABLO® 315	MONO	0,25	2,15	VATM 2,2 - CATM 022	VATM 5 - CATM 050	53	91
	A6	0,18	0,64	VFM/T 037	VFM/T 075	54	92
	B4	0,37	1,1	VFM/T 037	VFM/T 075	55	94
	B48	0,37 / 0,09	1,32 / 0,5	-	-	55	94
DIABLO® 355	MONO	0,25	2,15	VATM 2,2 - CATM 022	VATM 5 - CATM 050	55	94
	A6	0,18	0,64	VFM/T 037	VFM/T 075	56	95
	B4	0,37	1,1	VFM/T 037	VFM/T 075	57	98
	B48	0,37 / 0,09	1,32 / 0,5	-	-	57	97
DIABLO® 400	MONO	0,37	2,91	VATM 5 - CATM 050	VATM 7,5 - CATM 075	57	99
	A6	0,18	0,64	VFM/T 037	VFM/T 075	58	100
	B4	0,37	1,1	VFM/T 037	1K1	59	102
	B48	0,37 / 0,09	1,32 / 0,5	-	-	59	102
DIABLO® 450	A68	0,25 / 0,10	0,95 / 0,65	-	-	88	155
	B6	0,37	1,23	VFM/T 037	VFM/T 075	88	155
	B612	0,37 / 0,06	1,47 / 0,7	-	-	88	155
	D4	0,75	1,9	VFM/T 075	2K2	90	158
	D46	0,75 / 0,22	2,13 / 1,0	-	-	90	158
	D48	0,75 / 0,17	2,1 / 1,02	-	-	90	158
DIABLO® 500	A8	0,18	0,75	VFM/T 037	VFM/T 075	93	165
	B6	0,37	1,23	VFM/T 037	1K1	93	165
	B612	0,37 / 0,06	1,47 / 0,7	-	-	93	165
	B68	0,33 / 0,14	1,05 / 0,8	-	-	93	166
	F4	1,5	3,65	VFM/T 1K5	VFT 4	100	179
	F46	1,5 / 0,44	3,74 / 1,6	-	-	100	178
	F48	1,5 / 0,35	4 / 1,81	-	-	99	176
DIABLO® 560	B8	0,37	1,6	VFM/T 037	1K1	100	179
	D6	0,75	2,2	VFM/T 075	2K2	100	179
	D612	0,75 / 0,1	2,3 / 0,9	-	-	103	185
	D68	0,7 / 0,3	2,2 / 1,5	-	-	103	185
	G4	2,2	5	VFM/T 2K2	5K5	108	195
	G46	2,2 / 0,65	5,5 / 2,5	-	-	107	193
	G48	2,2 / 0,5	5,2 / 2,6	-	-	108	195
DIABLO® 630	D8	0,75	2,45	VFM/T 075	2K2	167	322
	E612	1,1 / 0,2	3,5 / 1,45	-	-	162	313
	E68	1,1 / 0,46	3,5 / 2,1	-	-	162	313
	F6	1,5	3,9	VFM/T 1K5	4K0	162	314
DIABLO® 710	E8	1,1	3,2	VFM/T 1K1	3K0	171	332
	G6	2,2	5,3	VFM/T 2K2	5K5	175	340
	G612	2,2 / 0,3	5,5 / 2,2	-	-	181	352
DIABLO® 800	G8	2,2	6,7	VFM/T 2K2	5K5	203	397
	I6	4	10	VFT 4K0	11K0	203	397
	I68	4 / 1,7	9,5 / 5,4	-	-	221	433
	I612	4 / 0,55	9,93 / 3,7	-	-	221	433

The SINGLE PHASE versions are not F400-120 approved – they are for comfort use.

For the DIABLO TWIN® version, double the above electrical data. Speed regulation may be provided, factory-prewired on the motor support in both VFM and VFT versions (see page 261). For the DIABLO TWIN® unit, it is possible to opt for 1 speed controller common to both motors. For a comfort/smoke extraction application slaved to a relay unit, only the VFT speed controller is compatible. This factory-wired and -fitted configuration is F400-120 / NF EN 12101-3 approved by the CSTB.



DIMENSIONS CHARACTERISTICS

DIABLO®

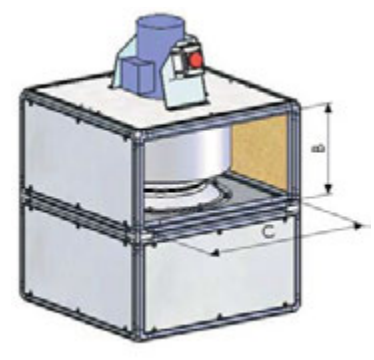
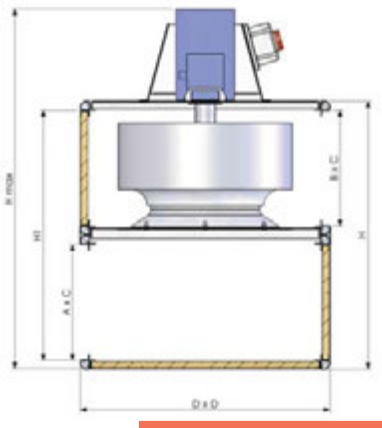

Unit model	A (mm)	B (mm)	C (mm)	D (mm)	H (mm)	H1 (mm)	H max (mm)	Variant weight (kg)	
								Sound insulation DIP	Double skin insulation DDP
DIABLO® 280	256	162	560	620	538	478	750	3	12
DIABLO® 315	256	171	560	620	547	487	760	3	12
DIABLO® 355	256	199	560	620	575	515	790	3	12
DIABLO® 400	256	256	560	620	632	572	850	4	13
DIABLO® 450	377	280	751	811	777	717	1030	6	22
DIABLO® 500	377	346	751	811	843	783	1110	7	23
DIABLO® 560	377	377	751	811	874	814	1180	7	25
DIABLO® 630	521	407	1021	1101	1088	1008	1430	12	40
DIABLO® 710	521	468	1021	1101	1149	1069	1490	12	42
DIABLO® 800	521	521	1021	1101	1202	1122	1620	13	44

DIMENSIONS CHARACTERISTICS DIABLO TWIN®

DIABLO®

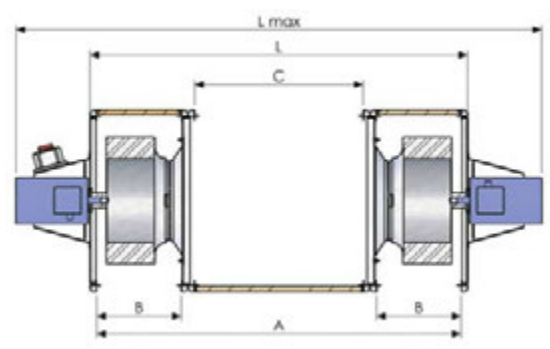
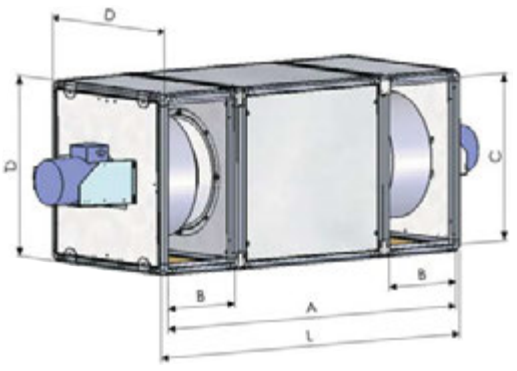

Unit model	A (mm)	B (mm)	C (mm)	D (mm)	L (mm)	L max (mm)	Variant weight (kg)	
							Sound insulation DIP TWIN	Double skin insulation DDP TWIN
DIABLO TWIN® 280	1004	162	560	620	1064	1488	5	20
DIABLO TWIN® 315	1022	171	560	620	1082	1508	5	20
DIABLO TWIN® 355	1078	199	560	620	1138	1568	5	21
DIABLO TWIN® 400	1192	256	560	620	1252	1688	6	23
DIABLO TWIN® 450	1431	280	751	811	1491	1997	10	37
DIABLO TWIN® 500	1563	346	751	811	1623	2157	10	38
DIABLO TWIN® 560	1625	377	751	811	1685	2297	11	41
DIABLO TWIN® 630	1995	407	1021	1191*	2075	2759	18	67
DIABLO TWIN® 710	2117	468	1021	1191*	2197	2879	19	71
DIABLO TWIN® 800	2223	521	1021	1191*	2303	3139	20	74

*Dont chassis H=90mm



PADLOCKABLE LOCAL SWITCH

Installed as standard over the whole range.



FACTORY-WIRED ASSEMBLY, RELAY UNIT Ref. CDF® AND SPEED CONTROLLER Ref. VFT

Separate or combined, these factory-fitted configurations are F400-120 / NF EN12101-3 approved by the CSTB. Only the VFT speed controller (three-phase input/output) is compatible with this certification in comfort/smoke extraction applications.



BAFFLE SILENCER KIT ref. KSB

Designed to be directly linked with the **DIABLO®** or **DIABLO TWIN®** housing, to the intake or to the expulsion. Plan a loss of load of 30 Pa.

KSB Model	Dimensions l x L x H (mm)	Weight (kg)	Attenuation dB(A)	
			INTAKE	OUTLET
280 - 400	620 x 620 x 620	26	PSA-7	PSA-6
450 - 560	811 x 811 x 811	48	PSA-8	PSA-7
630 - 800	1101 x 1101 x 1101	74	PSA-10	PSA-9

ACOUSTIC CHARACTERISTICS

DIABLO®

- The NSC3 dB(A) values (○) shown in the curves relate to the sound level at 3 m in free field for the unit connected at the intake and discharge by a duct with the same acoustic insulation as that of the unit.
- To obtain the acoustic power spectrum at the intake of the unit connected in dB(A) gain, take the sound power (PSA) shown on the curves (□) and the apply the correction factors in the table below depending on the unit model and its motor drive.

Unit model	Motor	ACOUSTIC SPECTRUM WEIGHTING							
		63	125	250	500	1000	2000	4000	8000
DIABLO® - DIABLO TWIN® 280	B4	-2	-2	-1	-1	-5	-10	-13	-20
DIABLO® - DIABLO TWIN® 280	A6	1	2	1	-1	-6	-10	-15	-23
DIABLO® - DIABLO TWIN® 315	B4	-3	-2	-1	0	-8	-10	-14	-22
DIABLO® - DIABLO TWIN® 315	A6	0	2	0	1	-9	-11	-16	-24
DIABLO® - DIABLO TWIN® 355	B4	2	1	1	-2	-5	-10	-13	-19
DIABLO® - DIABLO TWIN® 355	A6	5	5	2	-2	-6	-11	-15	-22
DIABLO® - DIABLO TWIN® 400	B4	1	0	0	-2	-5	-9	-12	-17
DIABLO® - DIABLO TWIN® 400	A6	4	4	2	-2	-6	-10	-14	-19
DIABLO® - DIABLO TWIN® 450	D4	-1	-1	-1	-1	-6	-9	-15	-19
DIABLO® - DIABLO TWIN® 450	B6	3	4	0	-1	-6	-9	-16	-22
DIABLO® - DIABLO TWIN® 500	F4	-3	-2	2	-3	-5	-10	-15	-20
DIABLO® - DIABLO TWIN® 500	B6	6	6	3	-4	-6	-11	-16	-24
DIABLO® - DIABLO TWIN® 560	G4	4	4	-1	-2	-7	-9	-11	-13
DIABLO® - DIABLO TWIN® 560	D6	8	9	0	-2	-7	-11	-12	-15
DIABLO® - DIABLO TWIN® 630	F6	8	4	0	-1	-7	-10	-15	-18
DIABLO® - DIABLO TWIN® 710	G6	3	0	0	-1	-6	-10	-13	-17
DIABLO® - DIABLO TWIN® 800	I6	0	6	2	-2	-6	-11	-15	-21

- If the **DIABLO®** or **DIABLO TWIN®** units have type DIP or DDP construction variants, add the attenuations shown below.

Unit model	Motor	Attenuation for DIP versions (acoustic insulation) and DDP (double-skin finish)							
		63	125	250	500	1000	2000	4000	8000
DIABLO® - DIABLO TWIN®	DIP	0	-1	-2	-4	-4	-6	-6	-6
	DDP	0	0	-1	-2	-3	-3	-2	-2

- To define the sound pressure level in free field at a certain distance, device on the floor, discharge free, unit connected upstream, subtract the values from the table below from the sound power level PSA (□) shown in the curves.

Distance (m)	1,5	3	4	5	7	10
Attenuation (dB)	11	17	20	22	25	28

Nota: Attenuations given for standard unit. For versions fitted with DIP and DDP options, also subtract the corresponding PSA (□) attenuations (see pages 262 and 263).



DIABLO® 280

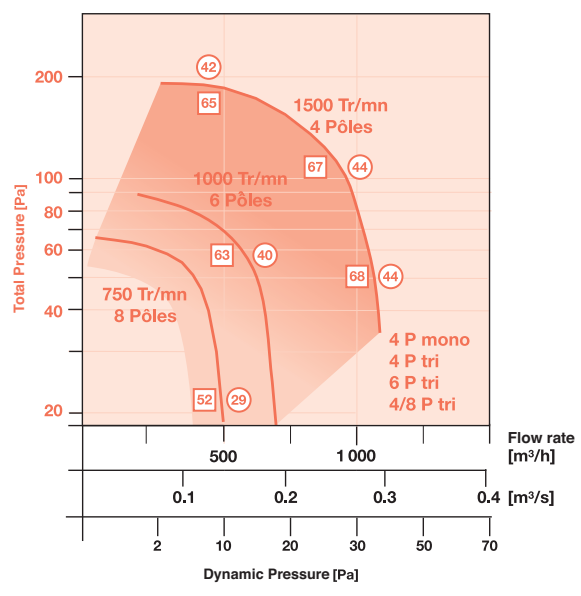

DIABLO® 315

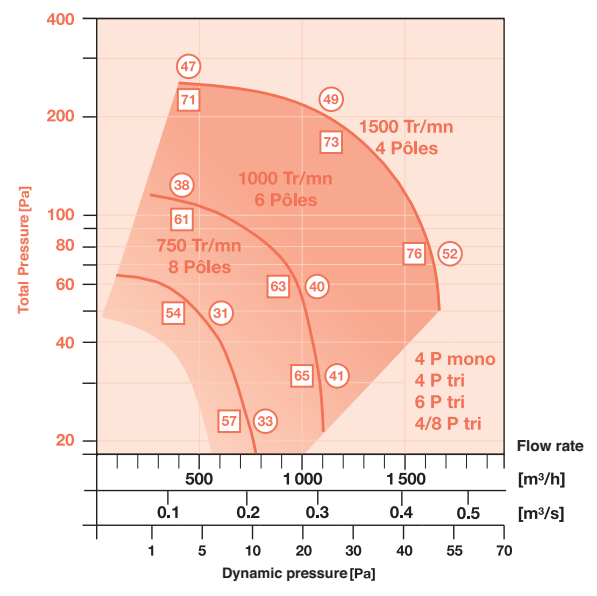

DIABLO® 355

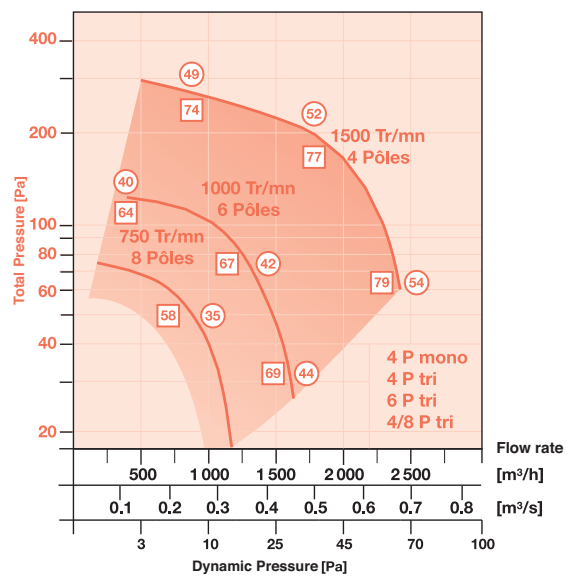

DIABLO® 400

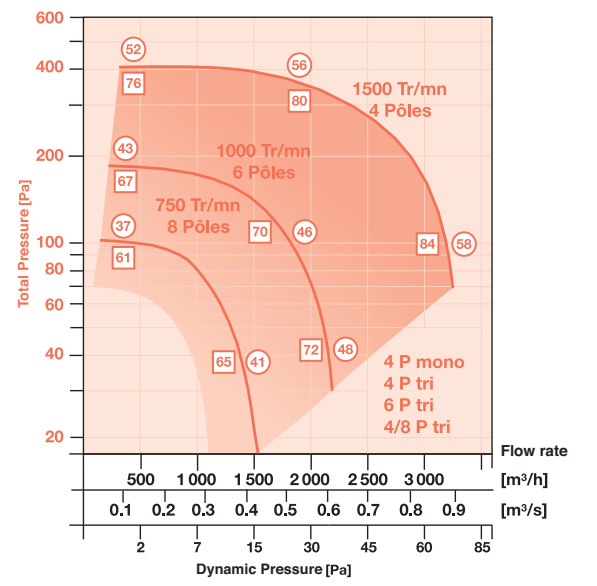

DIABLO® 450

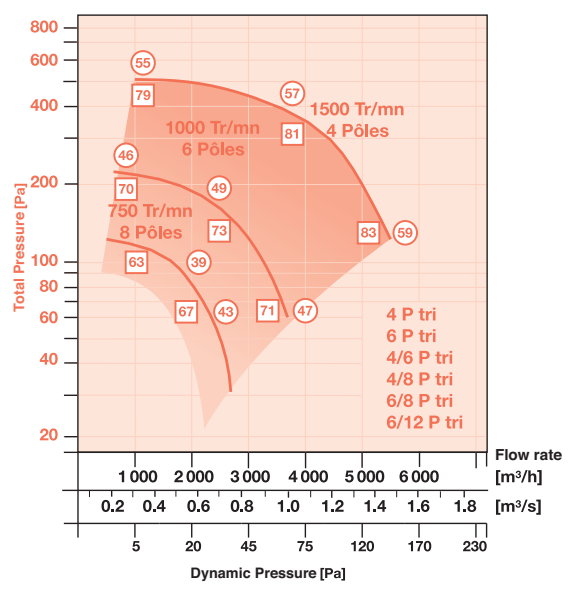

DIABLO® 500

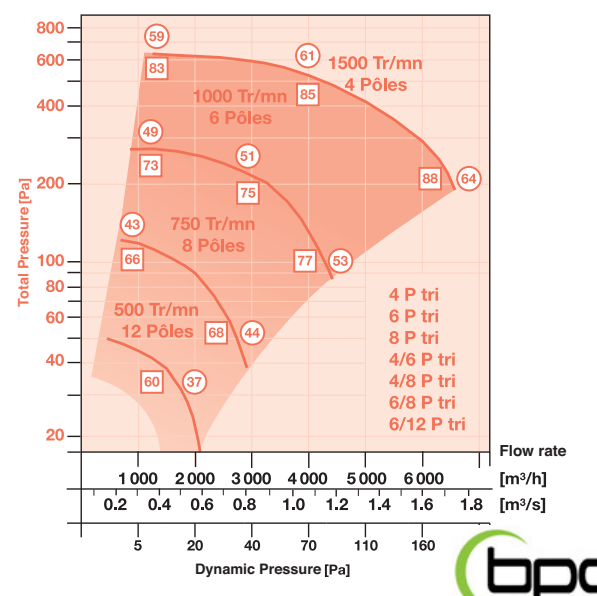



DIABLO® 560

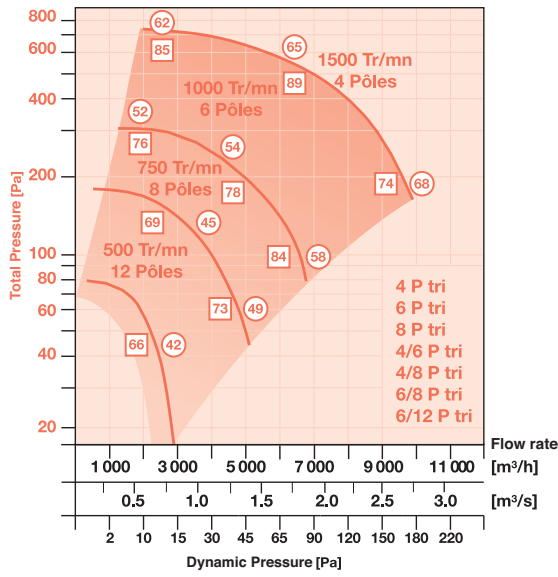

DIABLO® 630

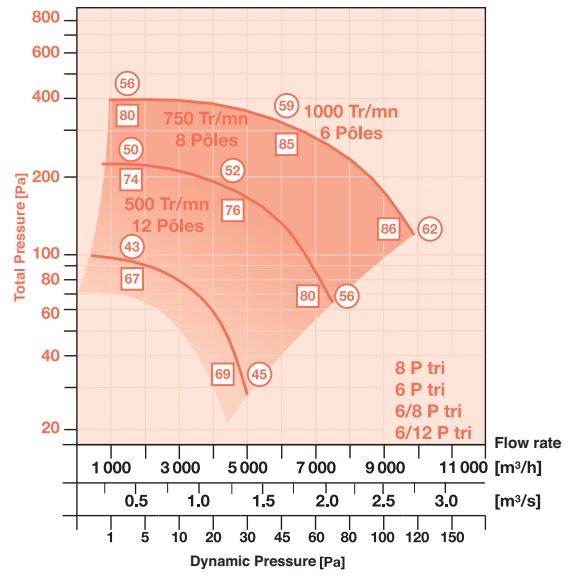

DIABLO® 710

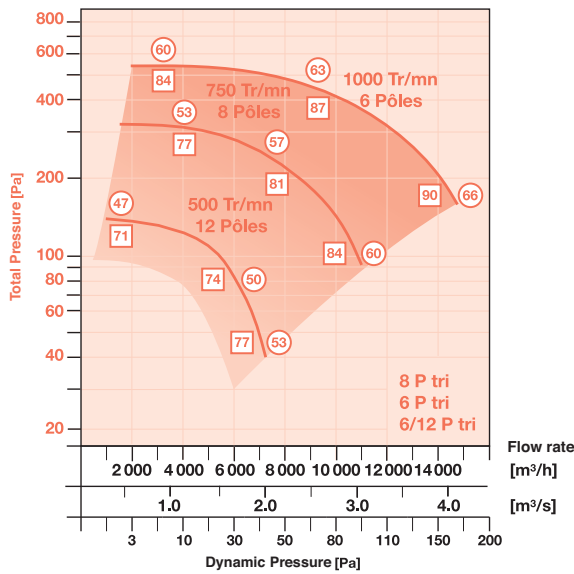

DIABLO® 800

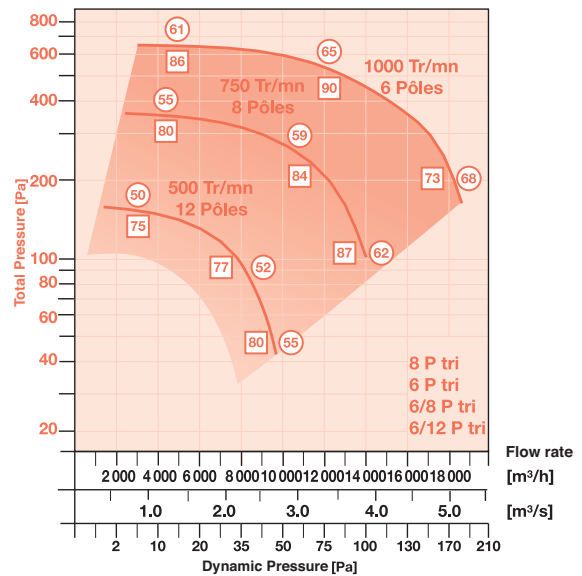

□ : Intake housing sound power in sheath dB(A), PSA ○ : Sound level at 3 meters in open field dB(A), NSC3.
 DIABLO® with sound insulation DIP: plan a mitigation of -7 dB(A) for NSC3 and -4 dB(A) for PSA.
 DIABLO® with sound insulation DDP: plan a mitigation of -9 dB(A) for NSC3 and -2 dB(A) for PSA.





DIABLO TWIN® 280

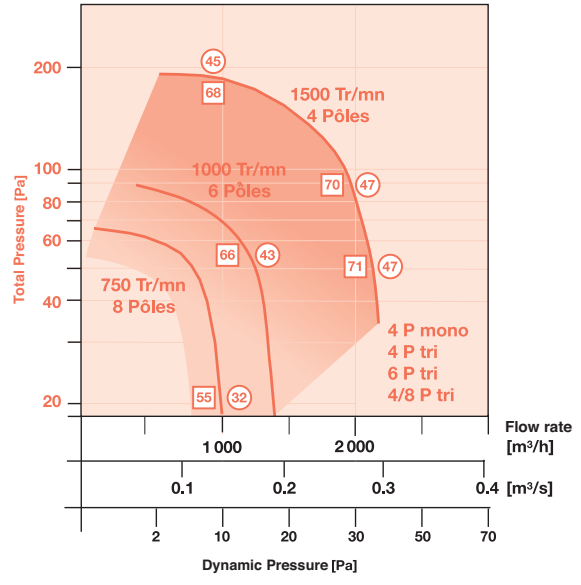

DIABLO TWIN® 315

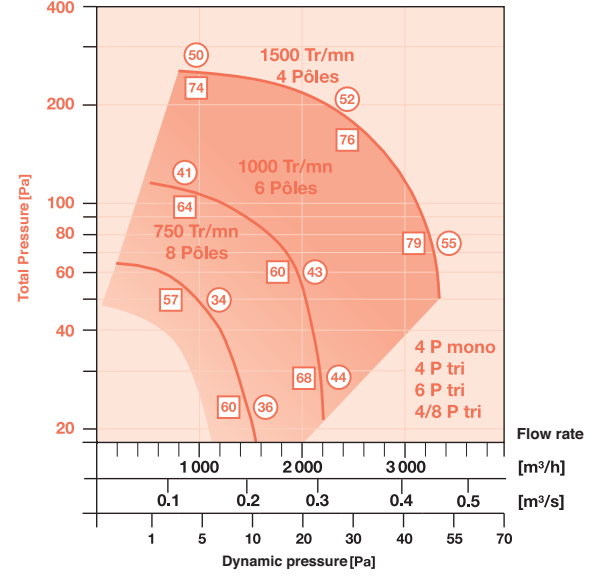

DIABLO TWIN® 355

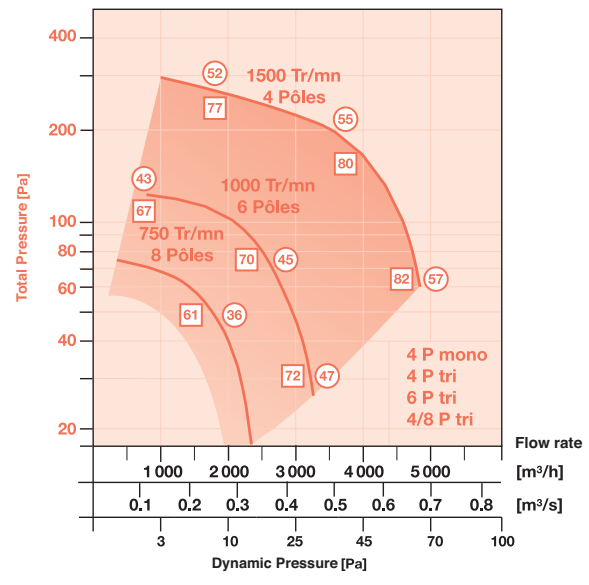

DIABLO TWIN® 400

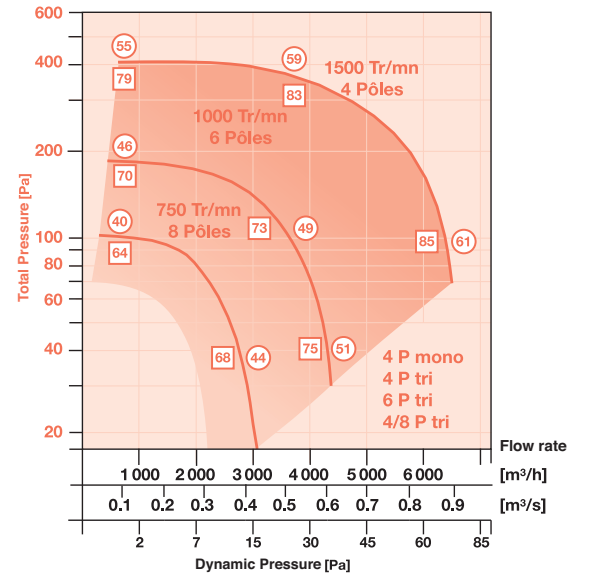

DIABLO TWIN® 450

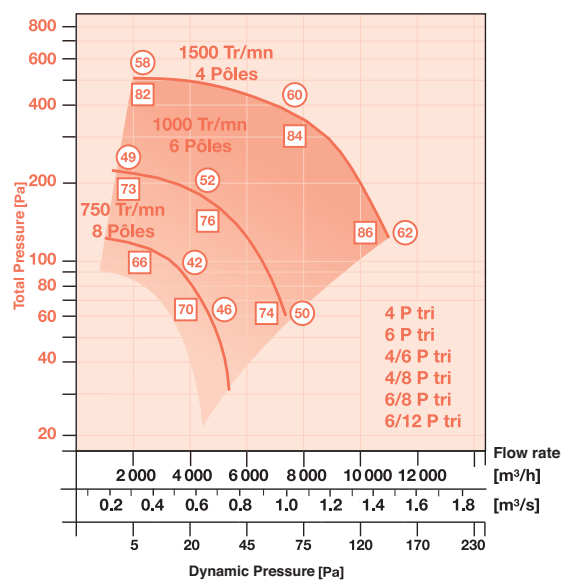

DIABLO TWIN® 500

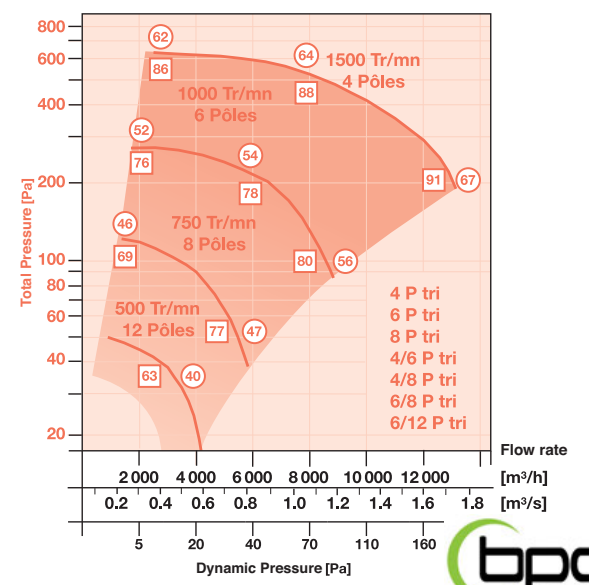



DIABLO TWIN® 560

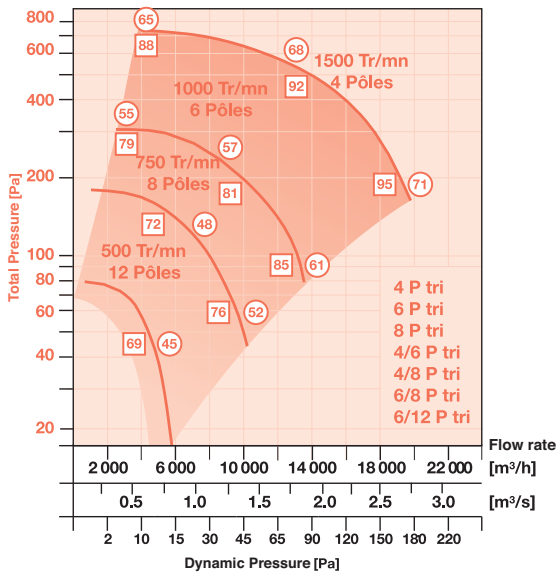

DIABLO TWIN® 630

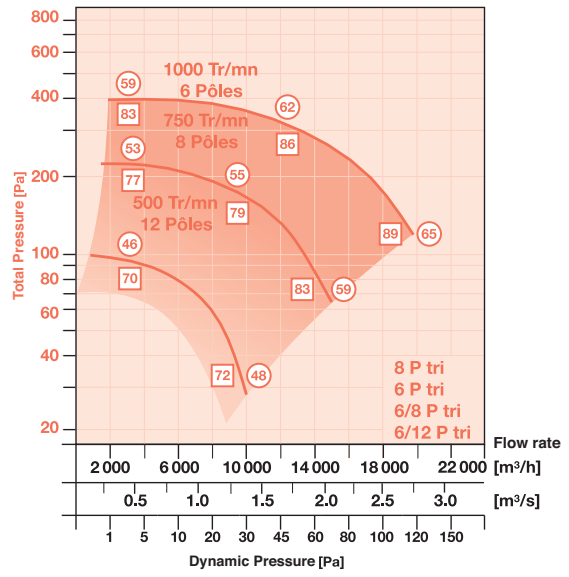

DIABLO TWIN® 710

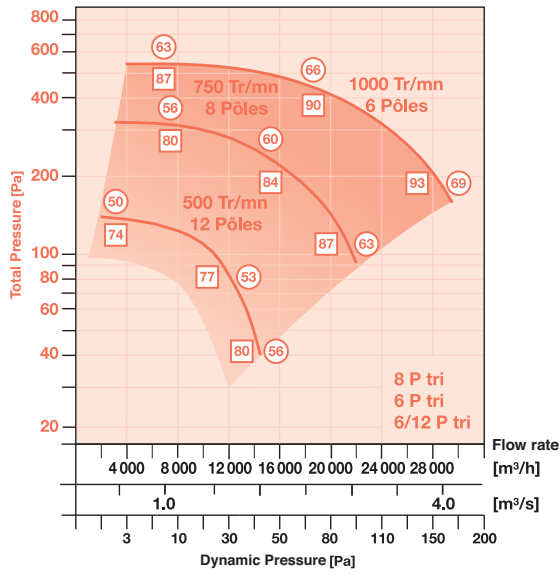

DIABLO TWIN® 800

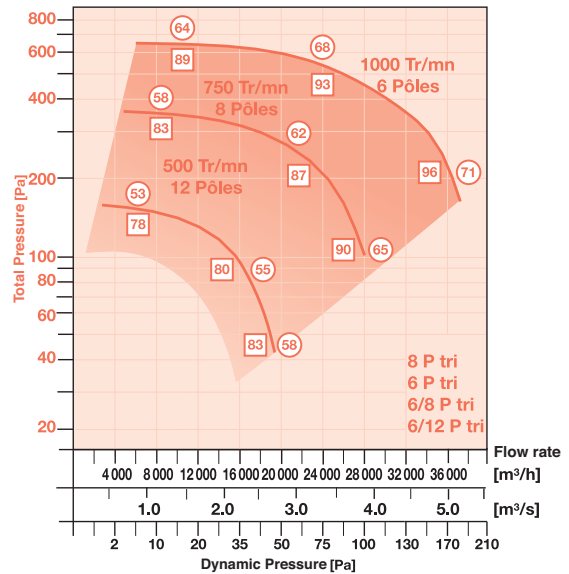

□ : Intake housing sound power in sheath dB(A), PSA. ○ : Sound level at 3 meters in open field dB(A), NSC3.
 DIABLO TWIN® with sound insulation DIP: plan a mitigation of -7 dB(A) for NSC3 and -4 dB(A) for PSA.
 DIABLO TWIN® with double skin insulation DDP: plan a mitigation of -9 dB(A) for NSC3 and -2 dB(A) for PSA.



DIABLO TWIN®

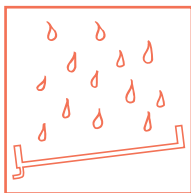

REMOVAL OF CONDENSATES ref. DEC

Located at the bottom of the unit, this condensate tray allows the **DIABLO®** or **DIABLO TWIN®** unit to be used where there are special operational constraints, particularly in professional kitchens, etc. Includes the PCB option.



ACOUSTIC INSULATION ref. DIP

Very high density 25 mm - 120 kg/m³ mineral wool providing powerful acoustic attenuation p261. Option F400-120 / NF EN12101-3 approved by the CSTB.



DOUBLE SKIN INSULATION ref. DDP

Insulation in 25mm – 60 kg/m³ high density mineral wool. Internal face in 10/10 galvanized metal sheet. External surface in 10/10 galvanized metal sheet, RAL7035 pre-lacquered. Meets the requirements of installations requiring regular maintenance of the unit and a significant reduction in radiated sound levels. Option F400-120 / NF EN12101-3 approved by the CSTB.

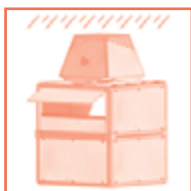

DIABLO® EXTERIOR KIT REF. KED

This kit includes a motor cover, bird-resistant mesh on the intake and a rain shutter on discharge.

▲ This rain shutter includes the non-return valve function.



DIABLO TWIN® EXTERIOR KIT ref. KED — TWIN

This kit has two motor covers, two cowls with mesh on the outlet and a hood.



DIFFERENTIAL PRESSURE SWITCH ref. DEP

Function: to detect a ventilation fault.

▲ Factory-fitting to **DIABLO®** or **DIABLO TWIN®** F400-120 / NF EN 12101-3 approved.



SPEED CONTROLLER ref. VFM/T

Function: regulation of fan speed by varying the power supply frequency.

VFM: 230V single phase supply and 230V three-phase output for comfort application. Not compatible for connecting via the relay unit. The VFT speed controller must be used for this.

VFT: 400 V three phase supply and 400 V three-phase output for comfort/smoke extraction application.

▲ Factory fitting and wiring of the speed controller in the motor compartment of the **DIABLO®** unit with remote potentiometer F400-120 / NF EN 12101-3 approved.



2-SPEED SINGLE-PHASE UNIT ref. CATM

Function: controls the **DIABLO®** single phase turret at 2 speeds either by remote control (CATM D version) or by weekly timer (version CATM H).

● This unit can be factory-wired and fitted if required.

INSTALLATION OPTIONS

DIABLO®

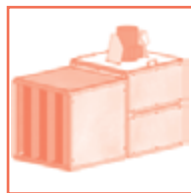

BAFFLE SILENCER KIT ref. KSB

Delivered with accessories for direct coupling to the **DIABLO®** or **DIABLO TWIN®** unit. This unit is weatherproof and so may be installed outdoors. Kit F400-120 / NF EN12101-3 approved by the CSTB.



SUPPORT FEET ref. PCB

Set of 4 feet for the **DIABLO®** range. For the **DIABLO TWIN®** range, set of 8 feet up to the 560 model. Beyond this, the units are fitted with a strengthened chassis as standard.



VIBRATION MOUNTS ref. PAV

Mounts selected to exactly match each unit model. Four mounts for the **DIABLO®** range. Six mounts for the **DIABLO TWIN®** 630, 710 and 800. Eight mounts for the other **DIABLO TWIN®** models.



FLEXIBLE SLEEVES ref. MTS — M0

Fire classification M0.

DIABLO®: Dimensions H1xC as standard, AxC if 2 intakes.

DIABLO TWIN®: Dimensions CxC at the intake and AxC at the discharge.

ELECTRICAL OPTIONS

DIABLO®

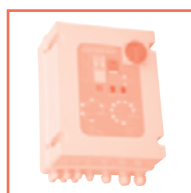

RELAY UNIT ref. CDF®

Function: the CDF® unit can be factory wired and fitted to the **DIABLO®** range.

▲ Factory-fitting F400-120 / NF EN 12101-3 approved.



SELF-REGULATING CONSTANT PRESSURE UNIT ref. LOBBY®

Function: adapts the fan rotation speed instantaneously to the requirements of the installation. Energy savings of 30 to 60% and a reduction of sound levels radiated by the system.

▲ Factory wiring and fitting for LOBBY-T version F400-120 / NF EN 12101-3 approved for comfort/smoke extraction application.



2-SPEED CONTROL BOX ref. CDA

Function: controls and protects two-speed motors.

DAHLANDER or SEPARATED WINDINGS, coupling with 24V local or remote control. Not compatible with the CDF unit.

● The box can be factory-fitted